

# AMSTRAD

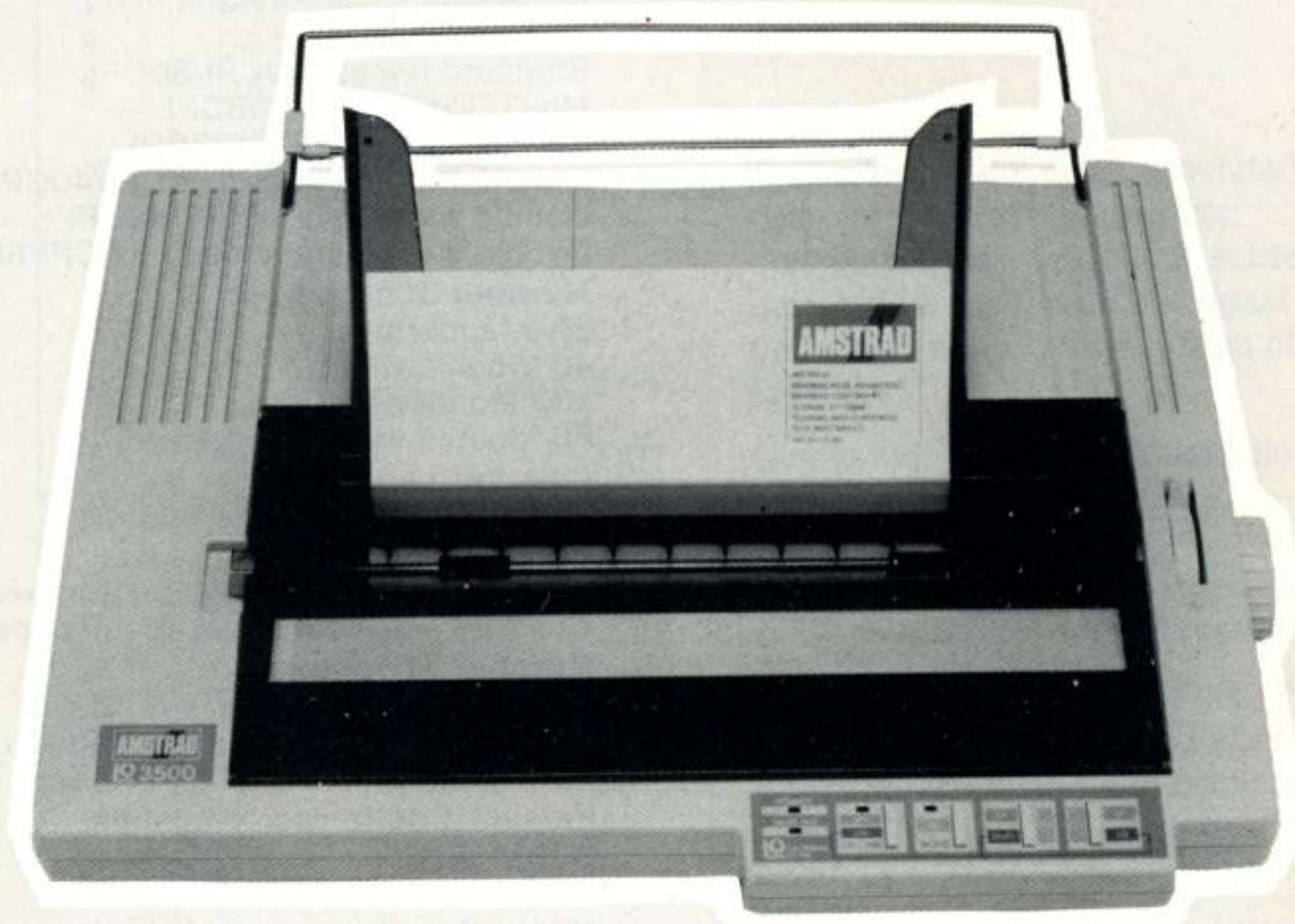

## LQ3500 PRINTER

SERVICE MANUAL



## CONTENTS

	Page
Safety Tests	2
Technical Specification	2
Interface Information	3
Dipswitch Setting Instructions	4
Block Diagram	5
Main PCB Components	6
Mains Input PCB	7
Power Supply PCB	7
Function Control PCB	7
Main PCB	8 & 9
Cabinet Drawing & Parts List	10 & 11
Chassis Exploded View & Parts List	12 & 13
Wiring Diagram	14 & 15
Electrical Parts List / Voltages	16

## TECHNICAL SPECIFICATION

### Print System:

Impact dot-matrix

### Print speed: standard typeface

12 CPI/160CPS, 10CPI/135CPS

### Condensed:

12CPI/74CPS, 10CPI/62CPS

### LQ:

12CPI/54CPS, 10CPI/45CPS

### Printing characteristics:

24-pin print head, capable of 8-pin emulation, 96 characters ASCII and italics, International character sets IBM Graphics character set.

### Normal character size:

2.1 (width) x 2.55 (height) mm

### Print sizes:

Standard (Pica) - 10CPI/80CPL

Mini (Elite) - 12CPI/96CPL

Condensed - 17CPI/137CPL

Double width standard - 5CPI/40CPL

Double width mini - 6CPI/48CPL

Double width condensed - 8.5CPI/68CPL

### Number of columns:

80 (standard)

40 (double width)

132 (condensed)

66 (double width condensed)

### Line feed speed:

200mS (1/6 inch)

### Paper type:

4.5 to 10 inches fan-fold (tractor feed)

4 to 9.5 inches cut sheet or roll paper (friction feed)

### Number of copies:

2 sheets (incl. original)

40 g.s.m. pressure-sensitive paper train

### Interface:

Parallel (Centronics compatible)

### Buffer size:

7Kbytes

### Mains Supply:

220-240V AC 50Hz

### Dimensions:

17.5 (width) inches

16 (depth) inches

4 (height) inches

(440 x 400 x 100mm)

### Weight:

5.9Kg

## SAFETY TEST

Printer is tested to the following specifications.

- Flash Test:** Test at 1.5kV RMS / 3 sec between the live and neutral poles of the mains lead and all accessible metal points on the exterior of the set.
- Insulation Resistance Test:** Test at 1.5kV RMS / 3 sec between the live and neutral poles of the mains lead and all accessible metal points on the exterior of the set to show a resistance greater than 4 Mohms.
- Earth Continuity Test:** The resistance of the mains lead shall not exceed 0.5ohms.

**PLEASE NOTE:** When any work is completed on this unit, correct safety tests must be carried out to ensure continued electrical safety.

**PLEASE NOTE:** All parts shown with the part number prefix  are Safety Items and must be replaced with similar items having an identical safety specification.

All those items may be purchased direct from AMSTRAD plc.

## AMSTRAD PLC

BRENTWOOD HOUSE, 169 KINGS ROAD, BRENTWOOD, ESSEX CM14 4EF.

Tele phone: 0277 230222. Telex: 995417 AMSELE G.



# Interface

PIN	DESIGNATION	I/O	DESCRIPTION
1	$\overline{\text{STROBE}}$	IN	Taking pin low enables receiving of DATA 0 to DATA 7. Minimum necessary pulse width is $0.5\mu\text{S}$ .
2	DATA 0 (LSB)	IN	8-bit data signal. Taking pin high or low corresponds to 1 and 0 respectively.
3	DATA 1		
4	DATA 2		
5	DATA 3		
6	DATA 4		
7	DATA 5		
8	DATA 6		
9	DATA 7 (MSB)		
10	$\overline{\text{ACKNOWLEDGE}}$	OUT	Active low output pulse generated when data entry and processing are completed. After this signal, subsequent data will be accepted. This signal is also generated when changing from off line to on line.
11	BUSY	OUT	Output high under any of the following conditions: a. Going off line. b. Paper feed or printing operation. c. When a control code is received.
12	PE	OUT	Output high when paper is out. (When on line, paper out is sensed after executing the paper feed command. When off line, paper out is always sensed.)
13	SELECT	OUT	On line and off line correspond to high and low respectively. When off line, DATA 0 to DATA 7 cannot be received.
14	$\overline{\text{AFD}}$		Taking pin low generates line feed.
15	NC		
16	0V		
17	CHASSIS GND		
18	+5V		+5V (50mA max) power supply output.
19	GND		Signal ground.
20	GND		Signal ground.
21	GND		Signal ground.
22	GND		Signal ground.
23	GND		Signal ground.
24	GND		Signal ground.
24	GND		Signal ground.
26	GND		Signal ground.
27	GND		Signal ground.
28	GND		Signal ground.
29	GND		Signal ground.
30	GND		Signal ground.
31	$\overline{\text{INPUT PRIME}}$	IN	Taking pin low initialises printer. Minimum necessary pulse width is $100\mu\text{S}$ .
32	$\overline{\text{FAULT}}$	OUT	Output low when off line.
33	GND		
34	NC		
35	+5V	OUT	
36	$\overline{\text{SLCT IN}}$	IN	Taking pin low or high sets printer on line or off line respectively (when the printer is not in error condition).



## DIP switch functions

Described below is how to adjust DIP switch DS1-7, and also how to adjust DS1-1, DS1-2, DS1-3 to select the required international characters. The following table indicates the functions of the remaining DIP switches.

SWITCH	FUNCTION	OFF	ON
DS1-1	International characters	See chapter 2	See chapter 2
DS1-2	International characters	See chapter 2	See chapter 2
DS1-3	International characters	See chapter 2	See chapter 2
DS1-4	Page length	11 inch	12 inch
DS1-5	Default skip perforation	Disable	Enable
DS1-6	Alarm bleeper	Disable	Enable
DS1-7	Print mode	Standard	LQ
DS1-8	SLCT IN signal	Not sent	Automatically sent
DS2-1	Paper out sensor	Enable	Disable
DS2-2	CR function	CR only	CR and LF
DS2-3	Zero character	Unslashed	Slashed
DS2-4	Reserved		
DS2-5	Character set	Epson	IBM
DS2-6	Unused		
DS2-7	Reserved		
DS2-8	Reserved		

**REMEMBER:** Always switch the printer *off* before adjusting the DIP switches.

## Signal timing

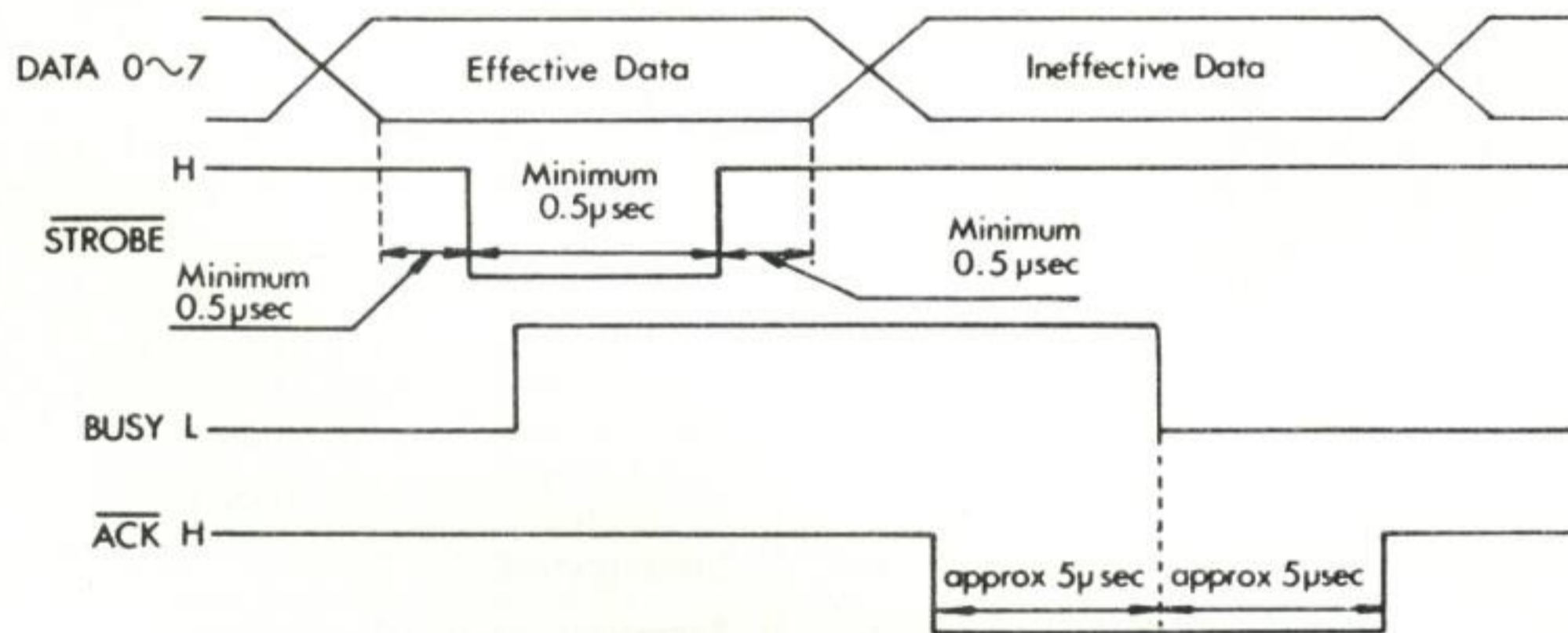

**DATA input waveform**



**BLOCK DIAGRAM**

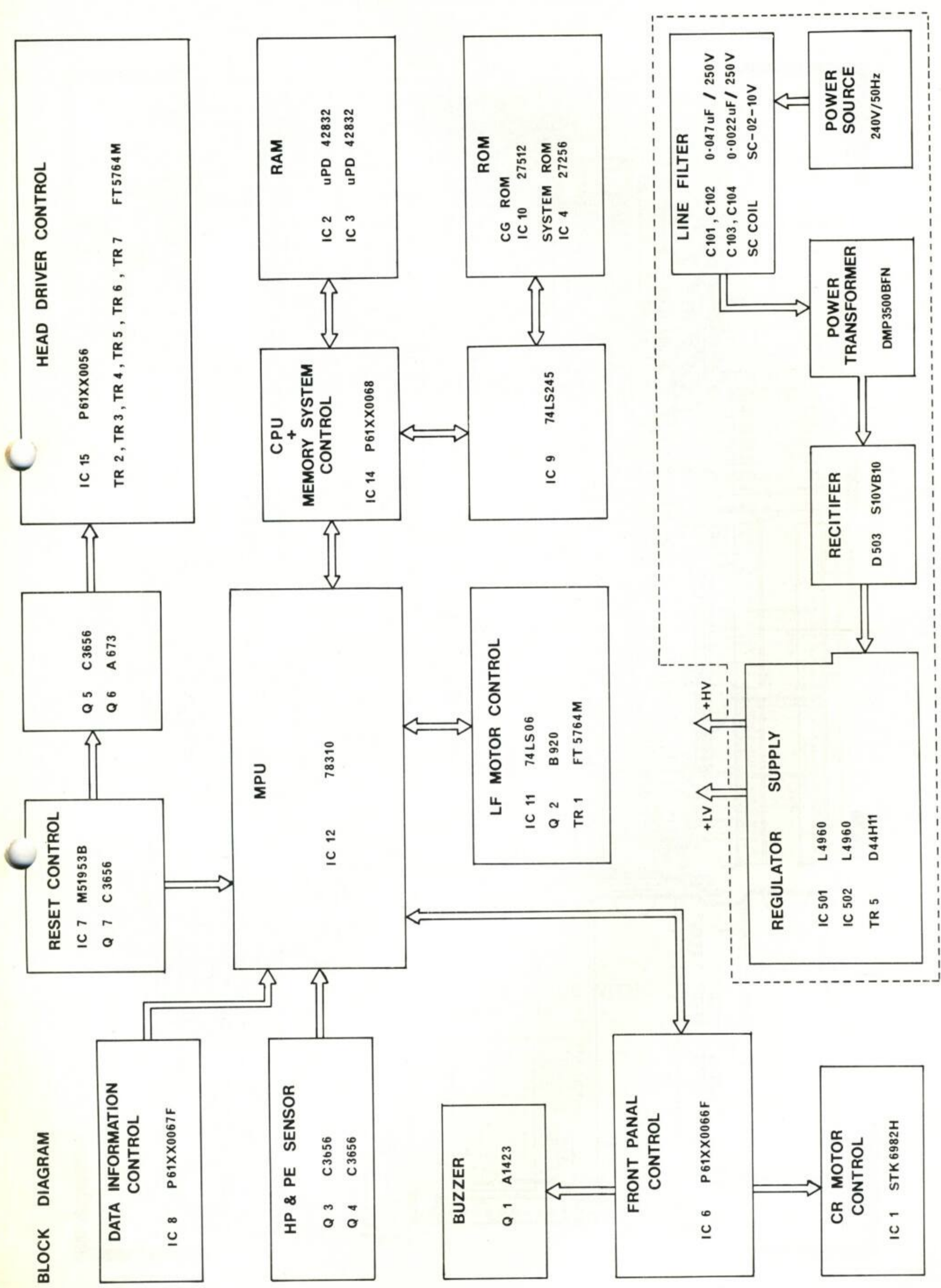



MAIN PCB WITH COMPONENTS

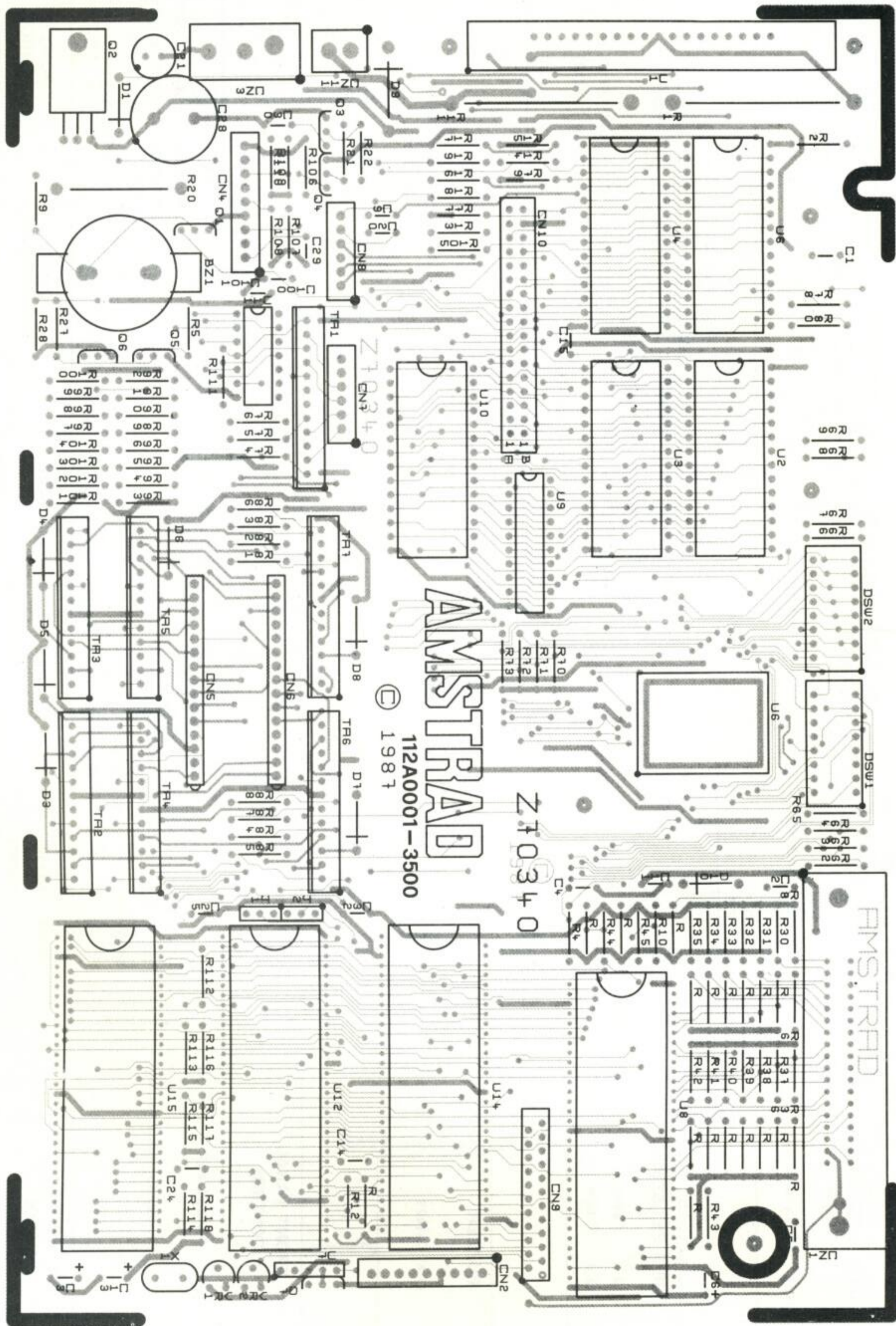



## MAINS INPUT PCB WITH COMPONENTS

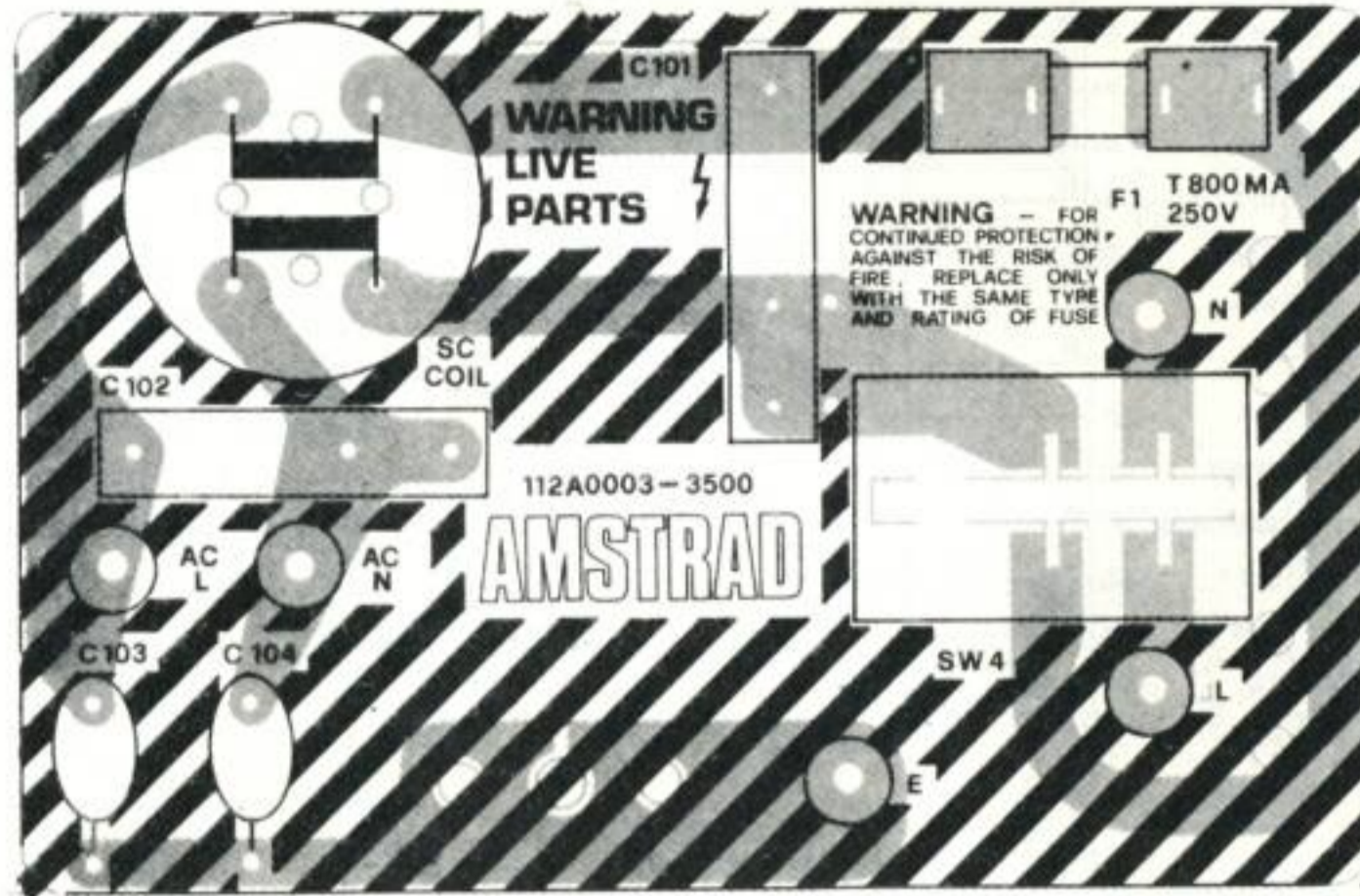

## POWER SUPPLY PCB WITH COMPONENTS

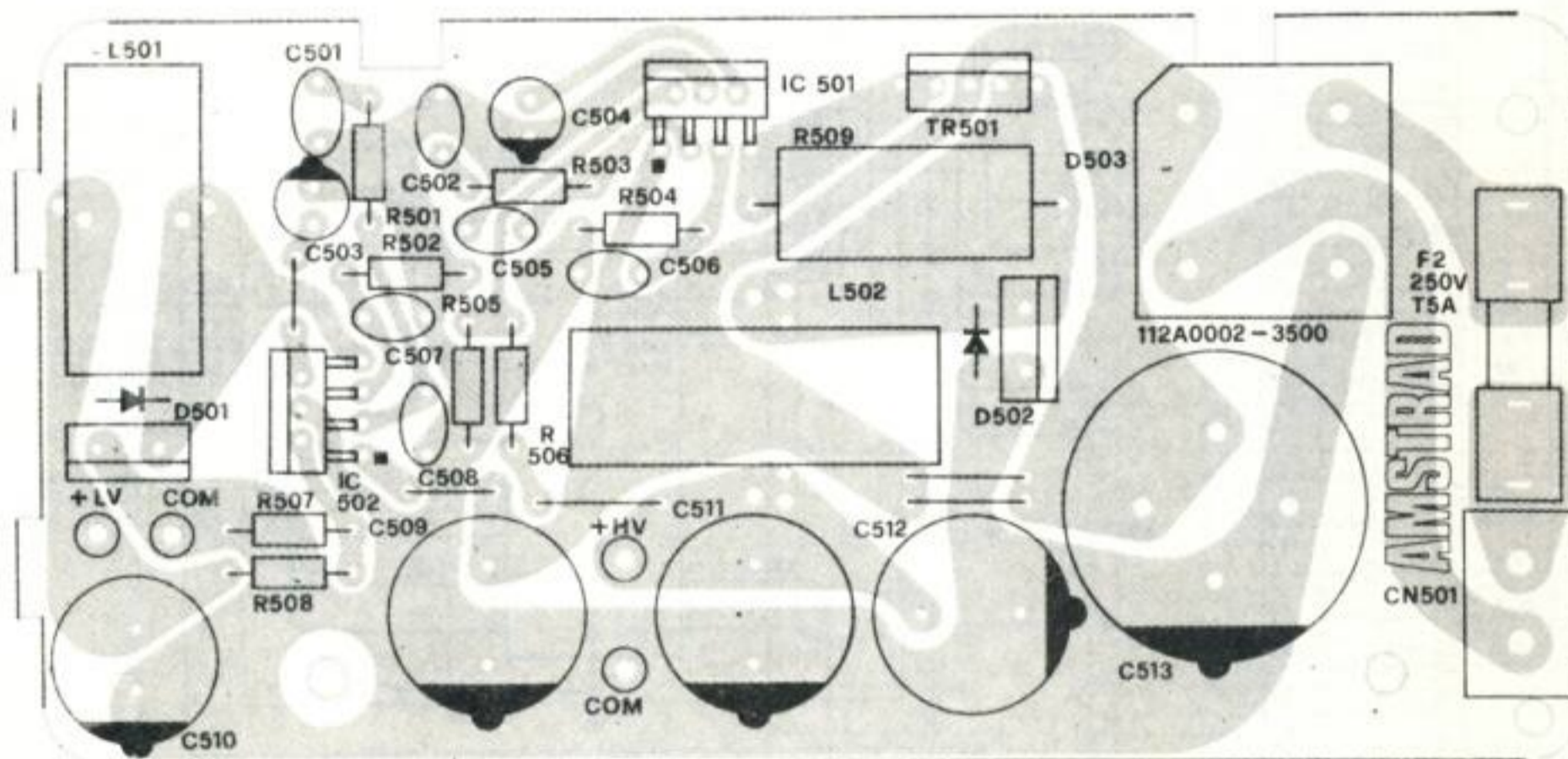

## FUNCTION CONTROL PCB WITH COMPONENTS

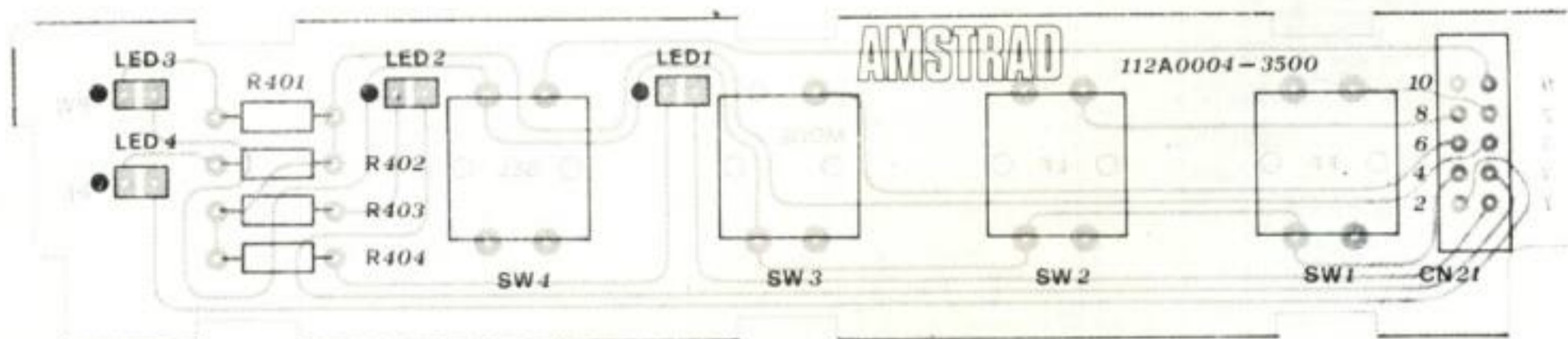



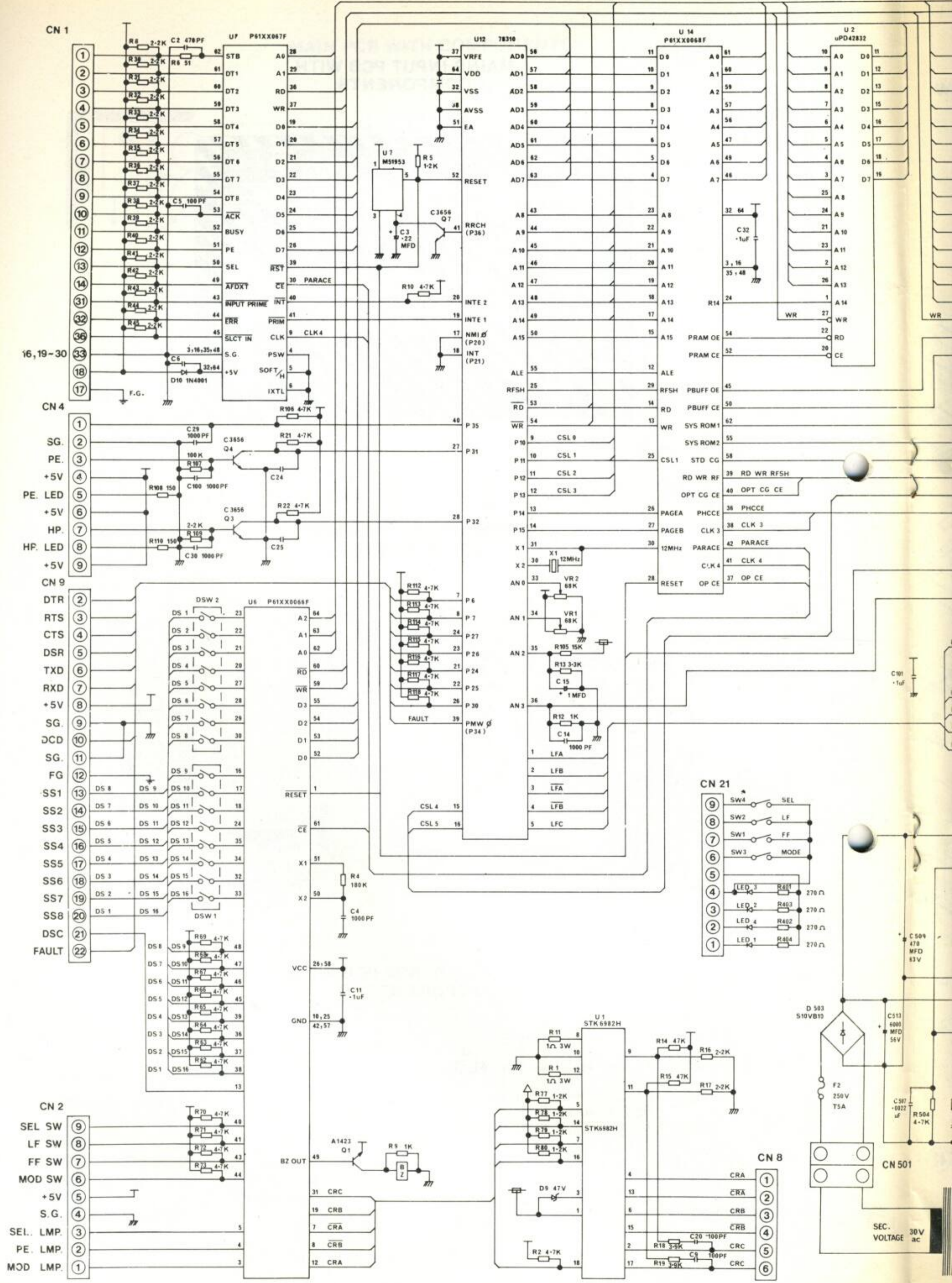



# IN CIRCUIT DIAGRAM

CN 10

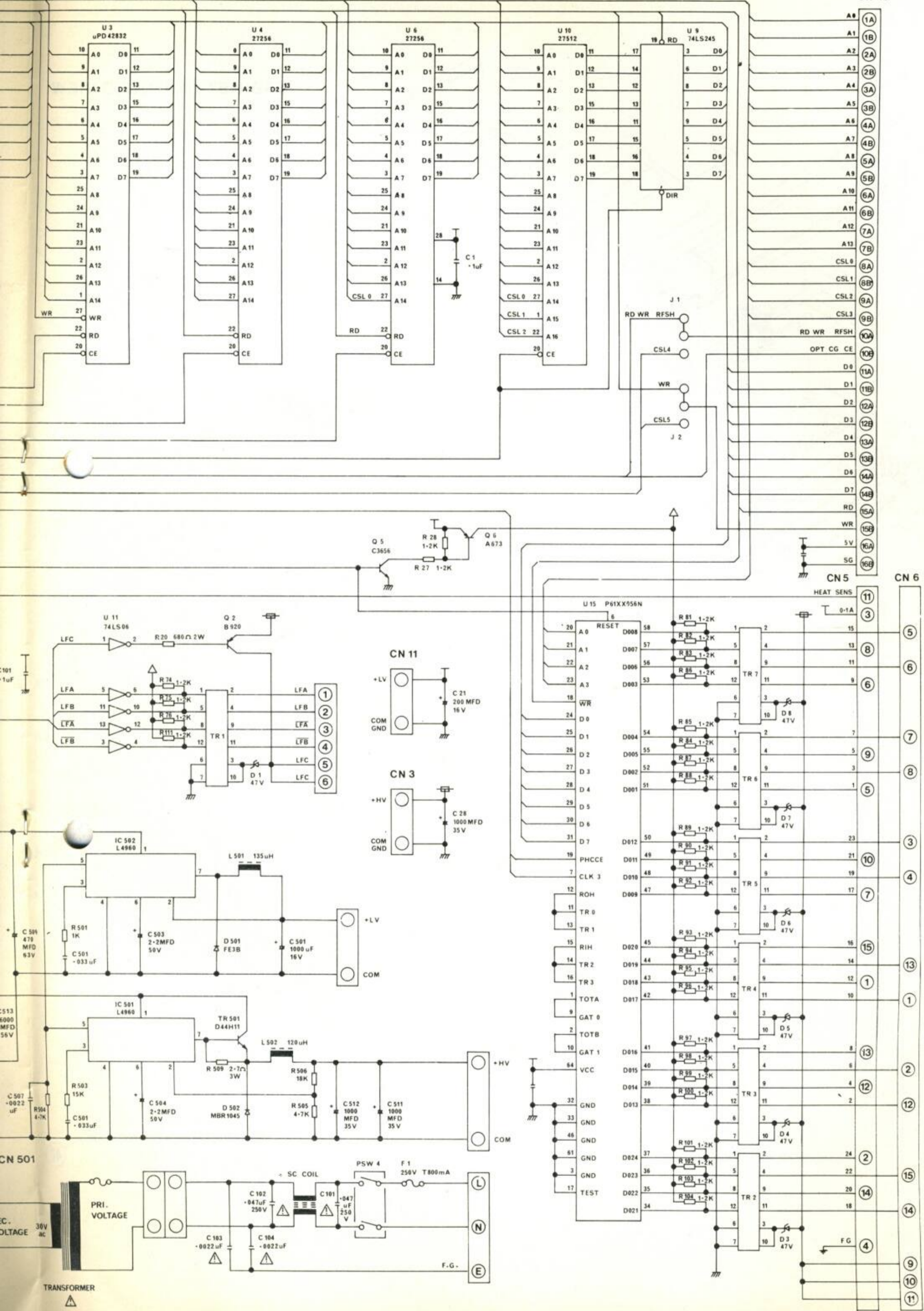



CABINET EXPLODED VIEW

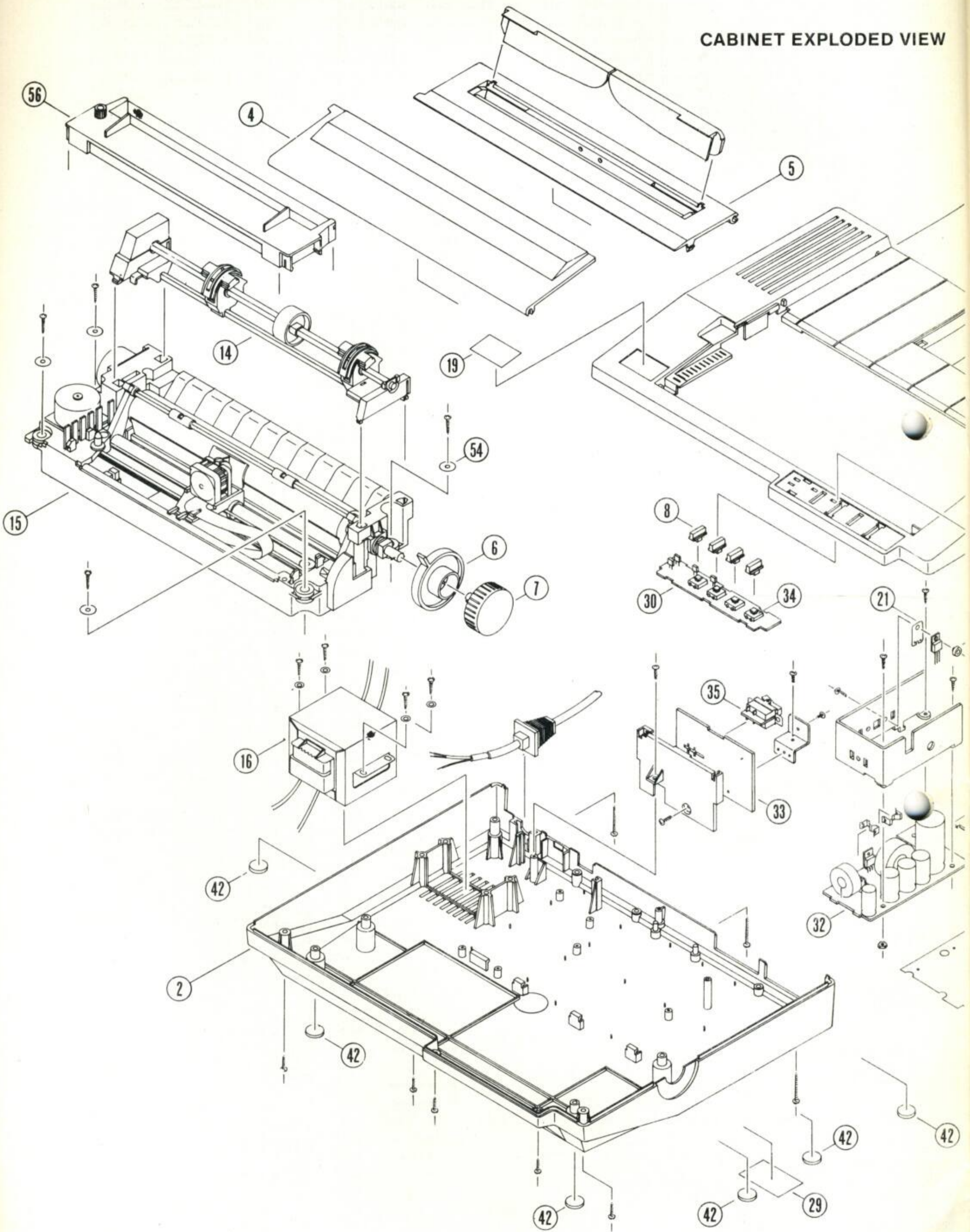



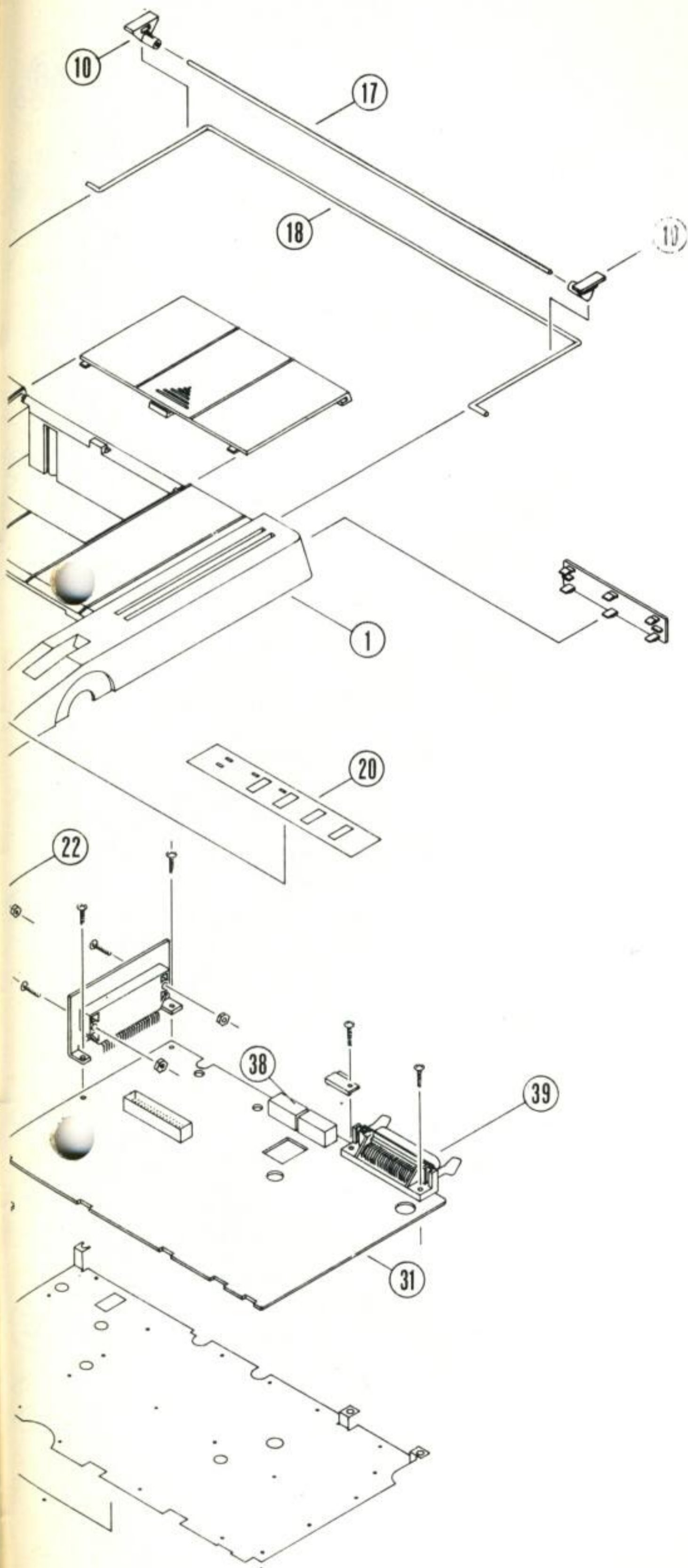

### CABINET PARTS LIST

Ref.	Description	Part No.
1	Top Cabinet Assy.	192027
2	Bottom Cabinet	192028
4	Dust Cover Front	192026
5	Dust Cover Rear Assy	192025
6	Paper Auto Feed Knob	192031
7	Paper Feed Knob	192030
8	Button Control	192029
10	Paper Support Plastic	192136
14	Tractor Feed Assy	191767
14	Tractor Feed Assy Replacement	171211
15	Printer Mechanism Assy	192100
16	Power Transformer	△ 192043
17	Rod Paper Support	192137
18	Main Paper Support	192138
19	Inlay	192139
20	Control Inlay	192140
21	Mica Washer	192141
22	Insulator Transistor	192142
29	Rating Label	192143
30	Control PCB	192042
31	Main PCB	192040
32	Power Supply PCB	192041
33	AC Input PCB	192144
34	Tact Switch	192145
35	Power Switch	△ 190714
38	Dip Switch 8 Way	190737
39	Centronics Socket	192146
42	Rubber Feet	192147
56	Ribbon	



# PRINTER MECHANISM EXPLODED VIEW

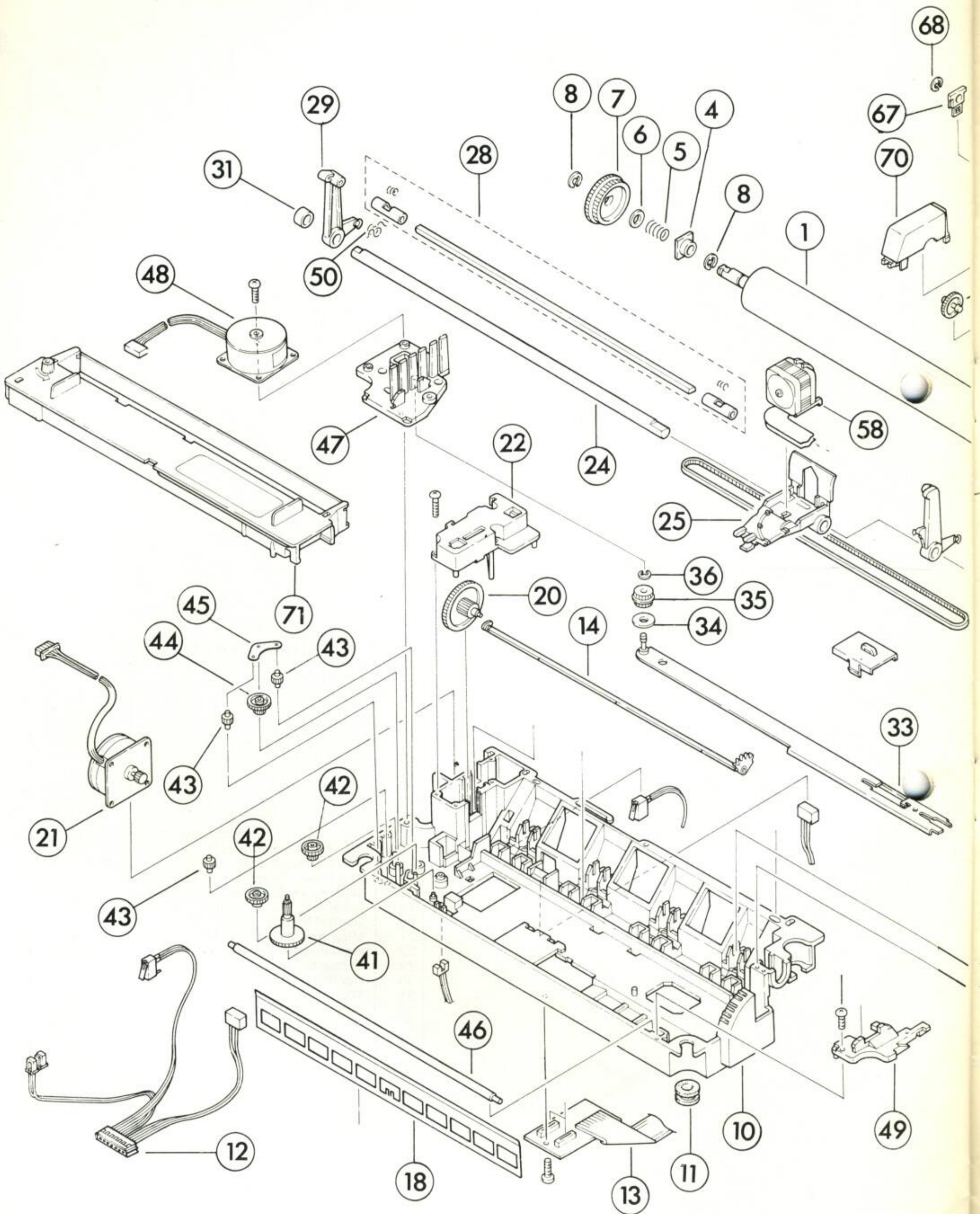



## CHASSIS PARTS LIST

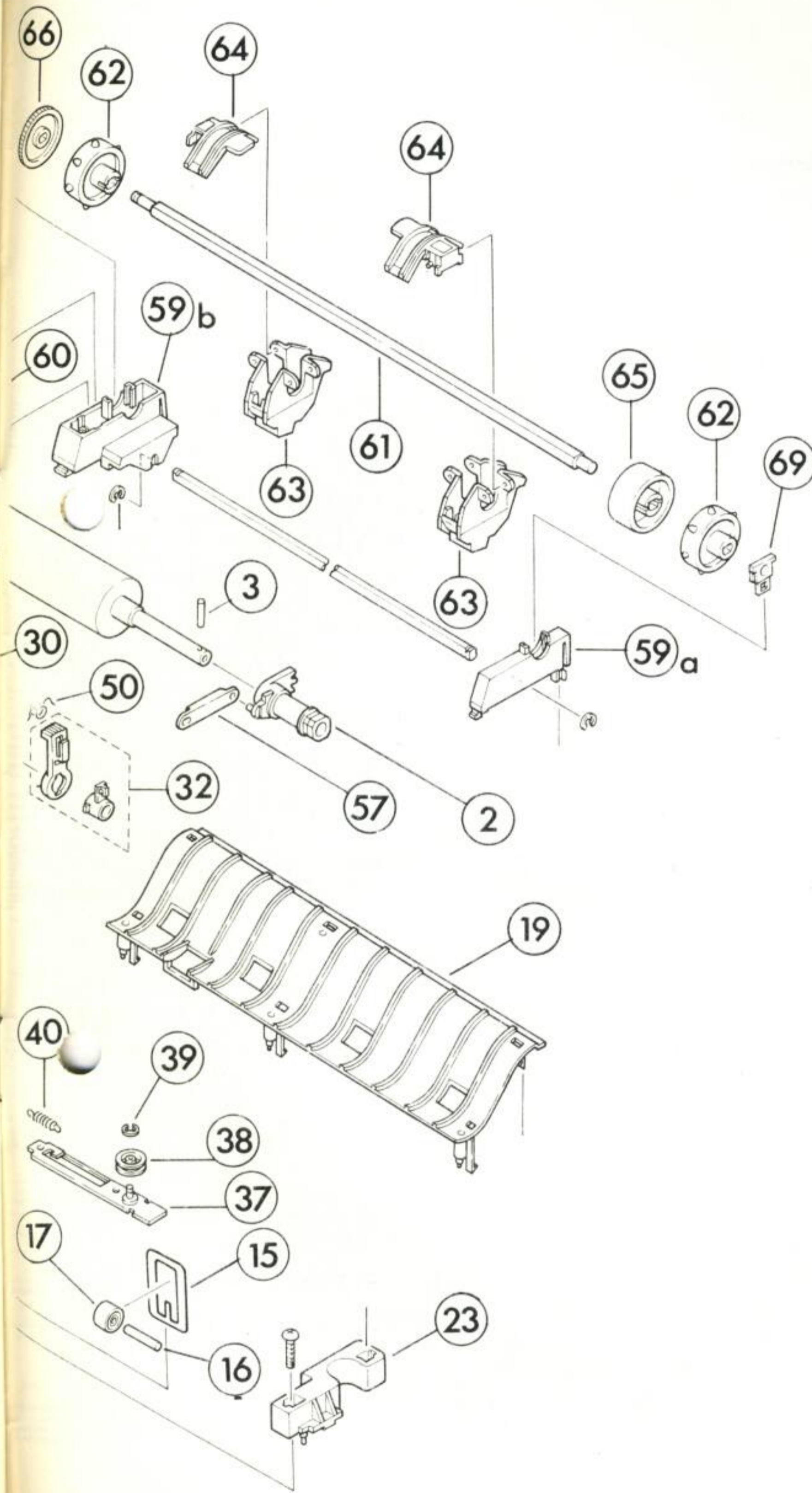

Ref.	Description	Part No.
1	Platen	192110
2	Release Sleeve	171702
3	Spring Pin	171703
4	LF Bearing	171704
5	LF Spring	171705
6	Poly Slider	171706
7	LF Gear D	192111
8	E Ring 6OZ	171708
9	E Ring 5OZ	171709
10	Frame	171710
11	Rubber Foot	171711
12	Set, Sensor	171712
13	Set, Head, P.C.B.	192112
14	Release Shaft	171714
15	Pressure Spring	192113
16	P Shaft	171716
17	Set, Pressure Roller	171717
18	Paper Press	171718
19	Paper Guide	171719
20	LF Gear C	192114
21	Set, LF Motor	192115
22	LF Gear Cover	171722
23	Cover A	171724
24	Carriage Shaft	192116
25	Set Carriage	192117
26	Set, Head Cable	171727
27	Head Bracket	171728
28	Set, Bail Shaft	171729
29	Bail Arm L	171730
30	Bail Arm R	171731
31	Carriage Sleeve A	192118
32	Set, Gap Lever	192119
33	Set, Carriage Bracket	171734
34	Set Collar	171735
35	Carriage Gear	171736
36, 39	E Ring 2OZ	171737
37	Set, Carriage Bracket	171738
38	Pulley	171739
40	Tension Spring	171740
41	RF Gear B	171741
42	RF Gear A	171742
43	Switch Gear	171743
44	RF Gear C	171744
45	RF Plate	171745
46	Carriage Sub Shaft	192120
47	RF Gear Cover	192121
48	Set, Carriage Motor	192122
49	Cover B	171750
50	Bail Arm Spring	171751
57	Release Link	171752
58	Print Head	192123
59	Tractor Frame	192124
60	Tractor Gear B	192125
61	Tractor Shaft	171756
62	Sprocket	171757
63	Tractor Bracket	171758
64	Tractor Cover	171759
65	Idle	192126
66	Tractor Gear A	171761
67, 69	Tractor Bearing	171762
68	E Ring 4OZ	171763
70	Tractor Gear Cover	171764
71	Ribbon	



# WIRING DIAGRAM

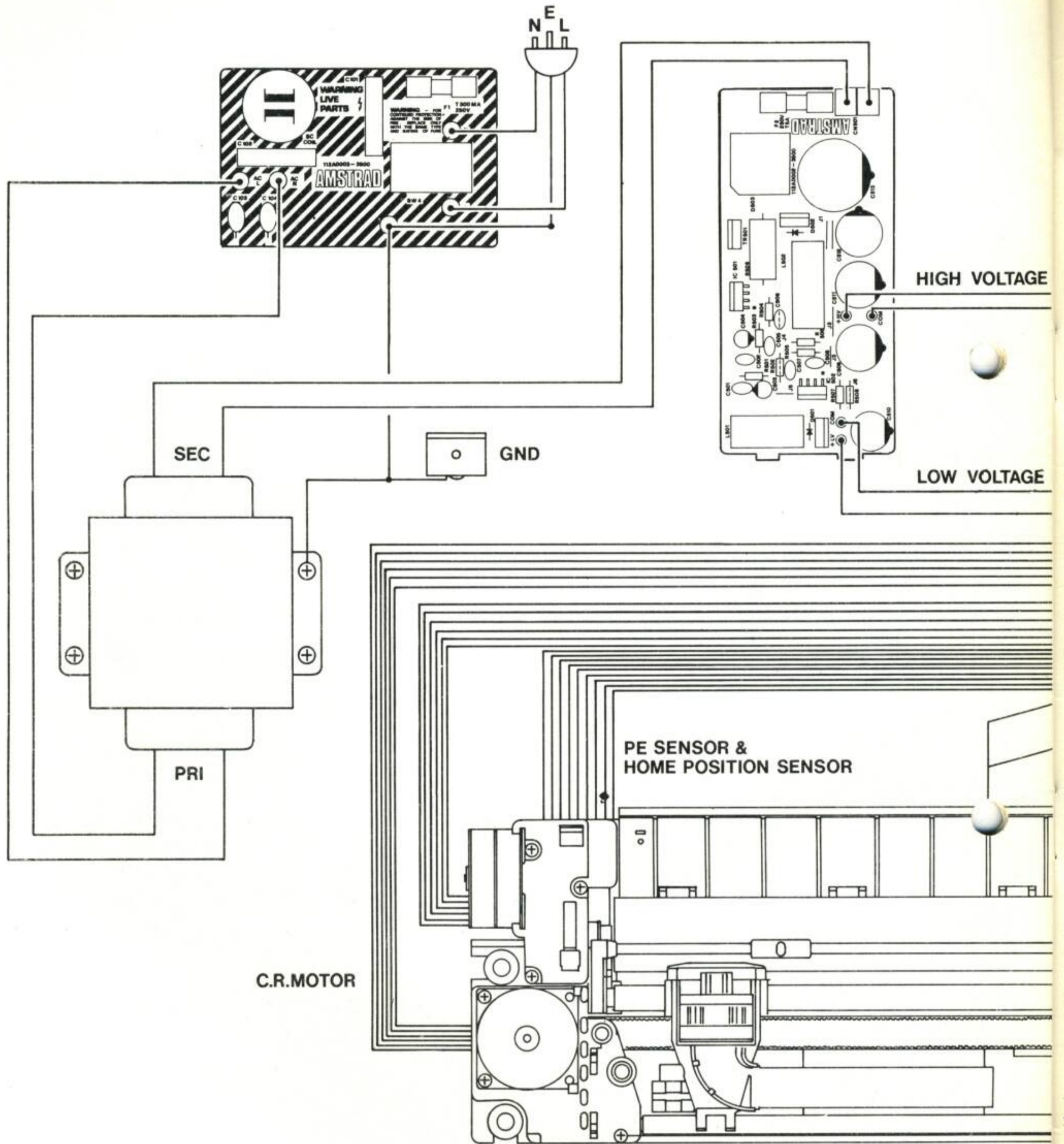



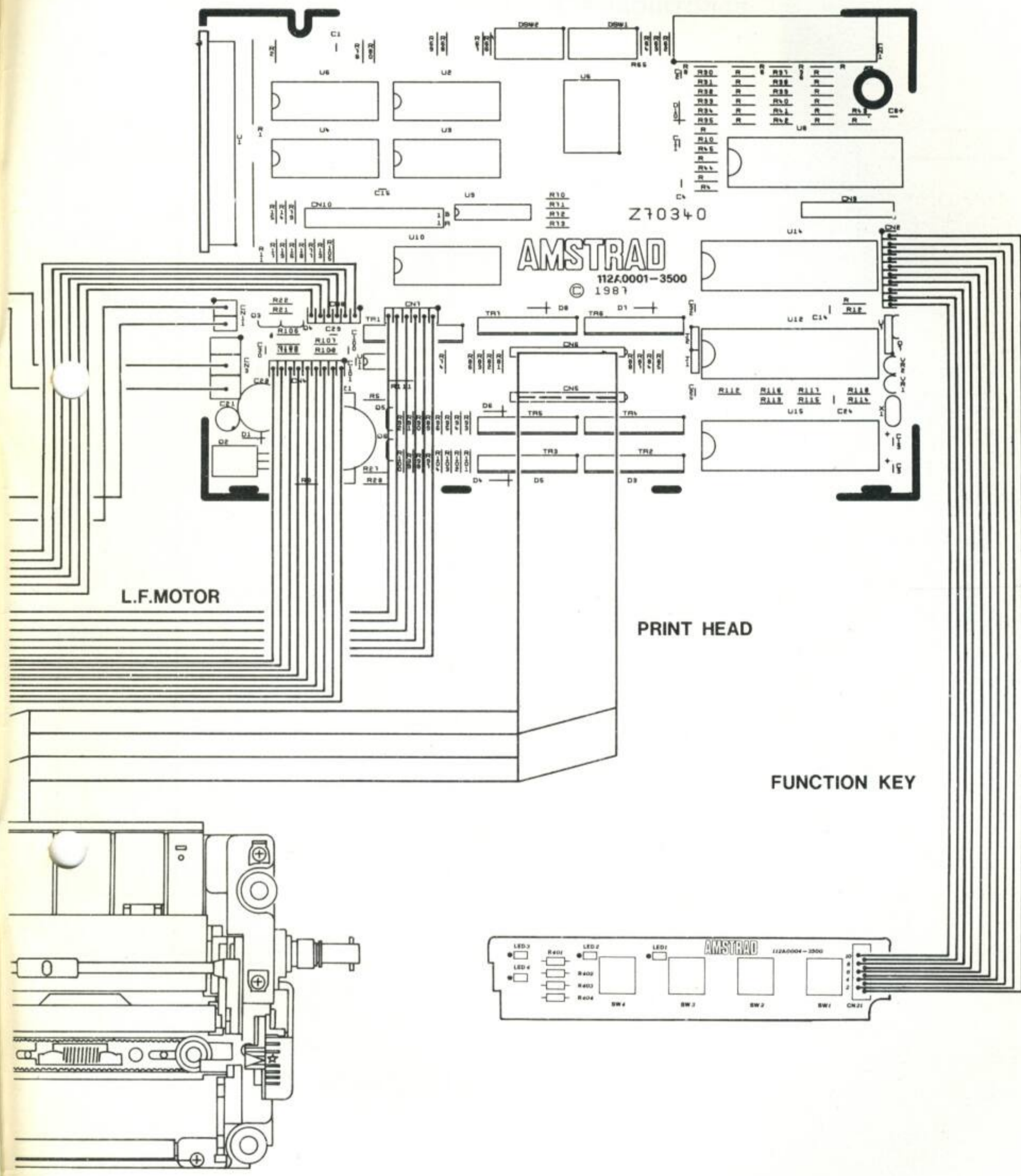



## ELECTRICAL PARTS LIST

Circ Ref.	Description	Part No.
<b>I.C.s</b>		
U1	IC STK6982H	192014
U2, U3	IC UPD42832	192003
U4, 5	IC 27256	192127
U6	IC P61XX0066F Panel Controller	192010
U7	IC M51953	192007
U8	IC P61XX067F Info Control	192011
U9	IC 74LS245	171393
U10	IC 27512	192008
U11	IC 74LS06	190729
U12	IC UPD78310	192004
U14	IC P61XX0068F Gate Array	192012
U15	IC P61XX056N Head Drive	192009
IC501, 502	IC L4960	192006
<b>Transistors</b>		
Q1	TR 2SA1423	192129
Q2	TR 2SB920	
Q3-5, 7	TR 2SC3656	192000
Q6	TR 2SA673	192001
TR501	TR D44H11 56S	192002
TR1-7	TR Array FT5764	192013
<b>Diodes</b>		
D1, 3-9	DZ K6KE47V	192018
D10	D 1N4001	15008
LED1, 2	LED Green	190744
LED3, 4	LED Red	190743
D501	D FEJB	192020
D502	D MRB1045	192019
D503	D S10VB10	192017
<b>Coils</b>		
SC Coil	Line Filter	△ 190740
Transformer	Mains Transformer	△ 192043
L501	Choke 135mH	192023
L502	Choke 120mH	192024
<b>Miscellaneous</b>		
X1	Crystal 12 MHz	192021
BZ	Piezo Bleeper	192045
DSW1, 2	8 Way Dip Switch	△ 190714
PSW4	Power On/Off Switch	
F1	Fuse 800mA(T)	192148
F2	Fuse 5A (T)	190960

Desc.	Circ. Ref.	Part No.
<b>Resistors</b>		
27ohm	R401-404	10017
51ohm	R6	10021
150ohm	R108, 110	10036
1kohm	R9, 12, 501	10061
1.2kohm	R27, 28, 74-80, 81-104, 111	10063
1.5kohm	R5	10065
2.2kohm	R8, 16, 17, 30-45, 109	10069
3.3kohm	R13	10070
3.9kohm	R18, 19	10075
4.7kohm	R2, 10, 21, 22, 62-73, 106, 112-118, 504, 505	10077
15kohm	R105, 503	10089
18kohm	R506	10091
47kohm	R14, 15	10101
100kohm	R107	10109
180kohm	R4	10115
1ohm/3W	R1, 11	△ 192130
2.7ohm/3W	R509	192131
680ohm/2W	R20	192132
68kohm	VR1, 2	192022
<b>Ceramic Capacitors</b>		
100pF	C5, 9, 20	24016
470pF	C2	190822
1000pF	C4, 14, 29, 30	1400215
0.1uF	C1, 6, 11, 31, 32, 101	24020
<b>Metalised Capacitors</b>		
0.0022uF/ 250V AC	C103, 104	△ 190824
0.047uF/ 250V AC	C101, 102	△ 190825
<b>Mylar Capacitors</b>		
0.002uF	C507	21000
0.033uF	C501, 502	21003
<b>Tantalum Capacitors</b>		
1uF/35V	C15	192133
<b>Electrolytic Capacitors</b>		
2.2uF/50V	C503, 504	809246
470uF/63V	C509	192134
1000uF/16V	C501	20118
1000uF/35V	C21, 28, 511, 512	200532
5000uF/56V	C513	192135

## VOLTAGES

### POWER SUPPLY SECTION UI IC STK6982H

Pin	Voltage	Pin	Voltage
1	24.9V DC	10	0V DC
2	0.2V DC	11	0.4V DC
3	24.5V DC	12	0V DC
4	0.2V DC	13	0.2V DC
5	1.2V DC	14	0V DC
6	0.2V DC	15	0.2V DC
7	0V DC	16	1.2V DC
8	0V DC	17	0.2V DC
9	0.4V DC	18	3.1V DC

### IC501

Pin	Voltage
1	38.5V DC
2	5.1V DC
3	1.3V DC
4	0V DC
5	2.1V DC
6	5V DC
7	25V DC

### IC502

Pin	Voltage
1	38.5V DC
2	5.1V DC
3	1.3V DC
4	0V DC
5	2.1V DC
6	5V DC
7	5V DC